

SR CORE

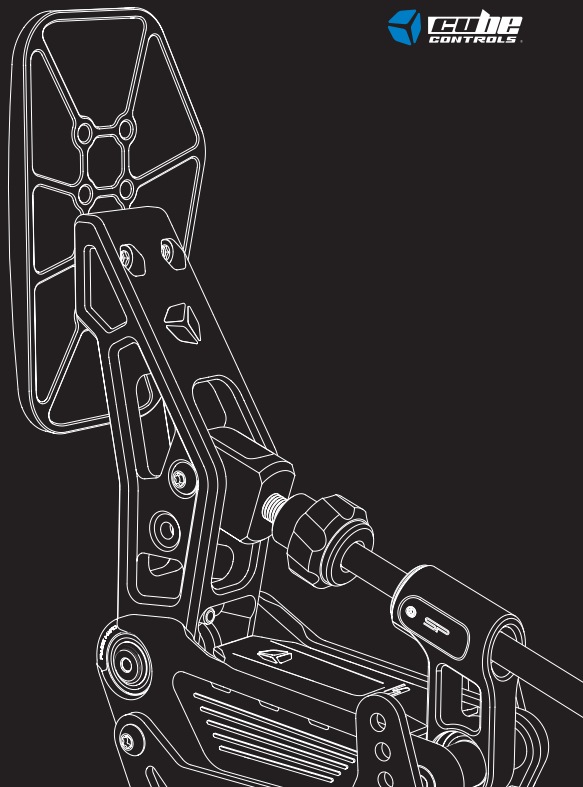

User guide

Before you start, please read the manual carefully before you use the sim racing equipment.

Any modifications, tampering, changes or unauthorized uses of the product will void the warranty.

The sim racing equipment has no waterproof feature, please keep it away from water, rain, moisture and other items containing liquid such as vape, cups, etc.

This sim racing equipment is designed for simulation purposes only.

Disconnect the USB cable from both sides if you will not use the product for a long time.





What you will find in the box

- ❖ SP01 Throttle Pedal
- ❖ SP01 Brake Pedal
- ❖ USB-C Connection Cable
- ❖ Brake Extension Cable
- ❖ Throttle Mounting Bracket (Light, Left, Right)
- ❖ Brake Mounting Bracket (Heavy, Left, Right)
- ❖ Additional Hard Blue Spring
- ❖ Additional Elastomer Kit (Soft Yellow, Medium Red, Hard Blue)
- ❖ Additional Throttle Spacer
- ❖ TX25 L Key
- ❖ HEX4mm L Key
- ❖ 8mm Wrench
- ❖ 8x M5x10 Button TX Screws (black)
- ❖ 8x M8x20 Button Hex Screws (silver)
- ❖ 8x M8 Nuts

SPECS

Main

- ✔ Precision press-fit ball bearings with Seegers
- ✔ CNC machined aluminum main structure from a single block of aluminum
- ✔ Compact design pushing the boundaries of compactness and weight
- ✔ Optimized FEM design for a cutting edge flex-free structure
- ✔ Custom brackets with adjustable main pedal body angle in 5° increments
- ✔ Redesigned mainspring with improved geometry
- ✔ Easier to mount brackets both in Stainless steel
- ✔ CNC machined 6061 and 7075 aluminum main structure
- ✔ Optimized FEM design for a cutting edge flex-free structure

Throttle

- ✔ Adjustable pedal throw by a dedicated knob on the main shaft
- ✔ Easy to reach spring preload adjustment
- ✔ Precision machined main shaft with high wear resistance plating
- ✔ Tolerance machined self-lubricating nylon sleeve for the smoothest operation
- ✔ 16 bit resolution hall sensor with improved readings
- ✔ USB-C connector for the main control electronics

Brake

- ✔ Custom lightweight die-cast pad faceplate with textured grip
- ✔ Fine-tuning spring preload option on the main pedal, and preload ring on the compression elements with counter knob
- ✔ Precision machined main shaft with high wear resistance plating
- ✔ Several springs and rubber dampers compression elements available
- ✔ Self-centering springs and dampers washers
- ✔ 200kg precision load cell with improved directly applied force cinematic
- ✔ 16-bit resolution

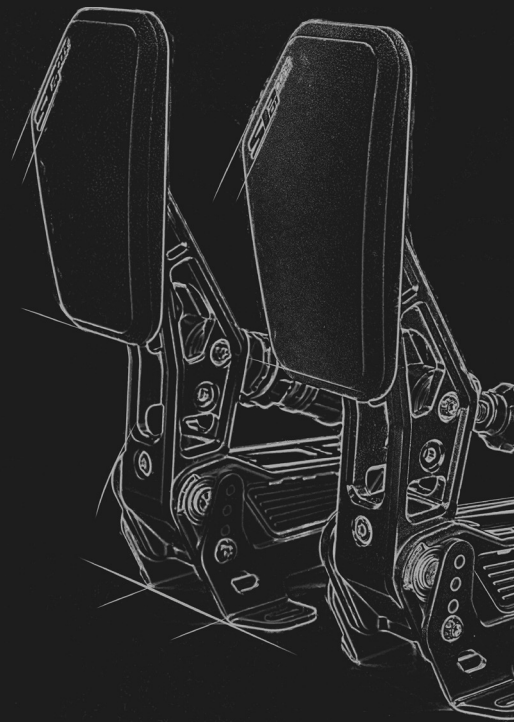

1. Let's get started

1.1 Mount the brackets

Both the Pedals will need their brackets to be mounted on the rig.

In order to do so, you will need to use the M5x10 Button TX Screws to mount the brackets to the side of the pedals (using the TX25 L Key you were supplied with).

Keep in mind that the two couple of brackets are different and specific: the brake ones have a 90° mounting angle and are in stainless steel, while the throttle ones are diagonal mounting and are in aluminium. Mounting the wrong brackets can result in damage to the pedals, so make sure you mount them correctly!

1.2 Set your favourite pedals angle

When mounting the brackets you will be able to choose one of the three different height levels. The brackets can also be inverted to mount the pedals on an upward or downward angle depending on your preferences.

Same as the first installation, you will need to tighten the screws according to the desired installation angle. Repeat the operation on both sides.

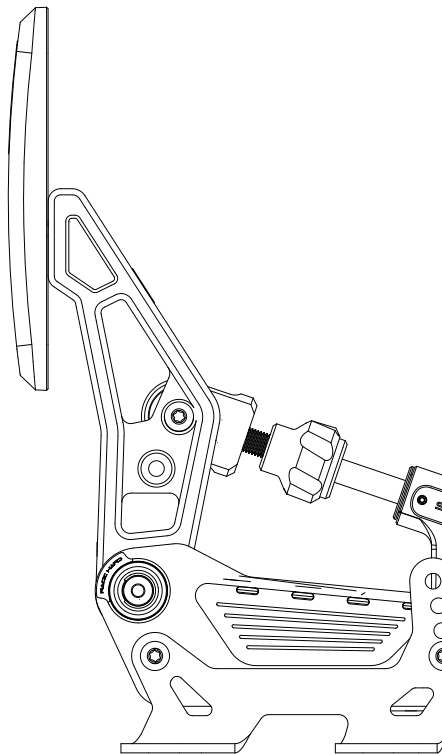

1.3 Installation

The next step is mounting the pedals to the simulator's plate: to do so you will need to use the M8x20 Button Hex Screws that you will find in the tools bag.

Remember, to lock the pedals in place you will need to tighten those screws with the M8 Nuts on the other side of the plate!

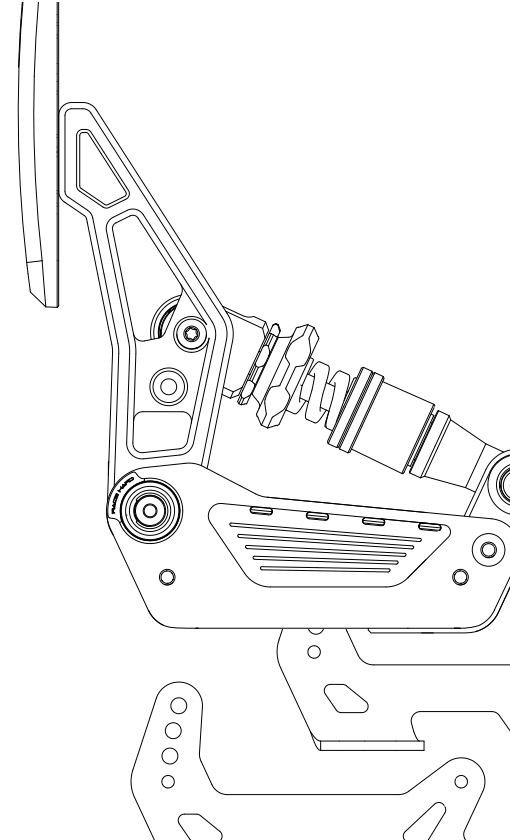

1.4 Connecting to the PC

To connect it to the PC, simply plug the USB-C and the 4-pin cable of the brake pedal on the rear of the throttle pedal.

If needed, use also the extension brake cable to connect it to the throttle pedal.

1.5 Calibrating the SP01

The first time you connect the SP01, you will need to download the PedalUI app to calibrate the pedals' axis.

After downloading it from the website and starting the program, you will see the Inputs page in which try out the pedals inputs.

There is the possibility the pedals' inputs could be not correctly recognized by the program at first.

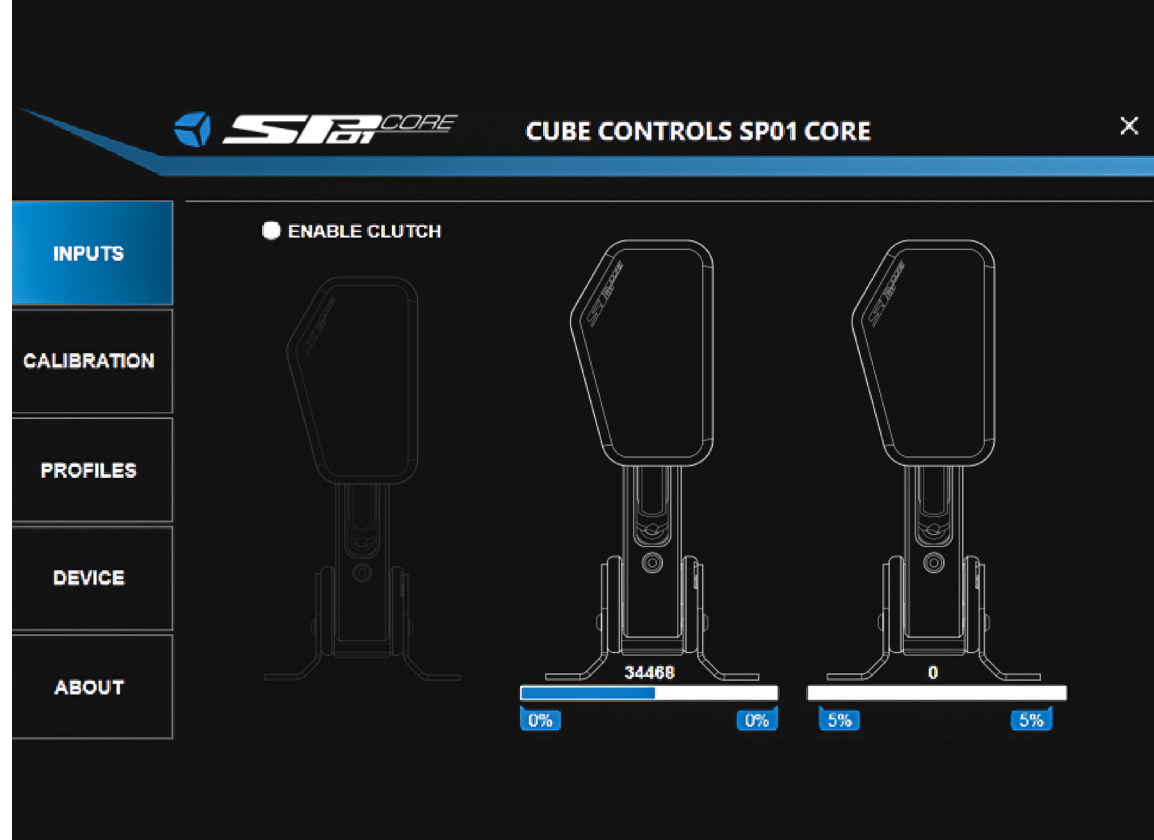

In this case, by clicking on the **"CALIBRATE"** section, you will be able to calibrate them. Then simply clicking **"CALIBRATE"** once again will make the RAW values of the pedals appear. Pressing now the pedals full-course will make the system set the correct minimum and maximum values.

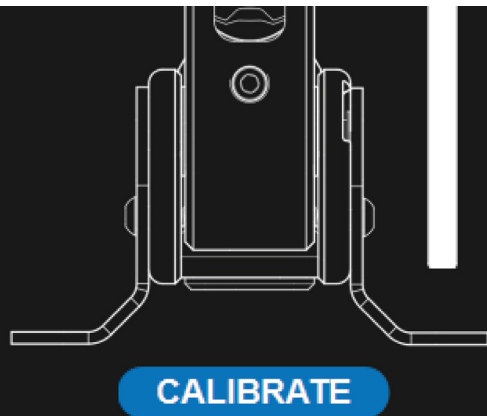

Make sure the pedals are calibrated at the maximum pressure you desire, this means that when you press **"SAVE"** the pedals are being pressed with the maximum pressure you desire. After that, simply click **"SAVE"**. Now the SP01 pedals are correctly calibrated, as you will be able to see on the Inputs page!



1.6 Customize and Save your Profiles

Last but not least, remember to try out the non-linear pedal output curves in the **PROFILES** section to fully customize your experience!

Each pedal's curve allows you to map non-linear output using its five zones (divided by 6 input parameters). You can make your own custom curves by simply moving the input points on the graph, to reach the desired feedback for pedals' throw.

Remember to Save once you're done and you also have the possibility to Import or Export profiles.

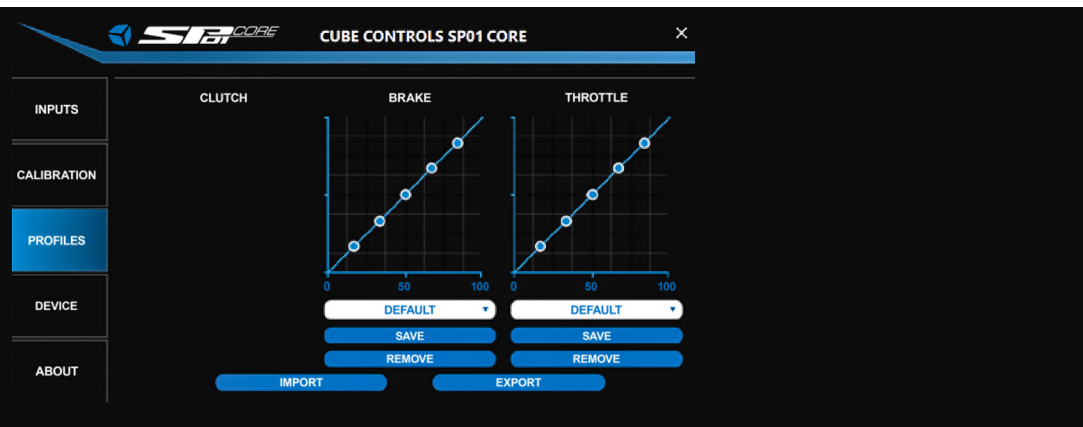

The screenshot shows the SIB CORE software interface for the CUBE CONTROLS SP01 CORE. The 'PROFILES' section is active, displaying three graphs for CLUTCH, BRAKE, and THROTTLE. Each graph shows a linear curve with five data points. Below the graphs are dropdown menus for 'DEFAULT', 'SAVE', and 'REMOVE' buttons. At the bottom, there are 'IMPORT' and 'EXPORT' buttons.

2. Adjustments

2.1 Pad Adjustments

Both pads can be adjusted to one's preferences. The brake pad can be set in four different positions moving the two M5x10 screws on the back. Simply remove them using the TX25 key, reposition the pad as you see fit and secure the screws again.

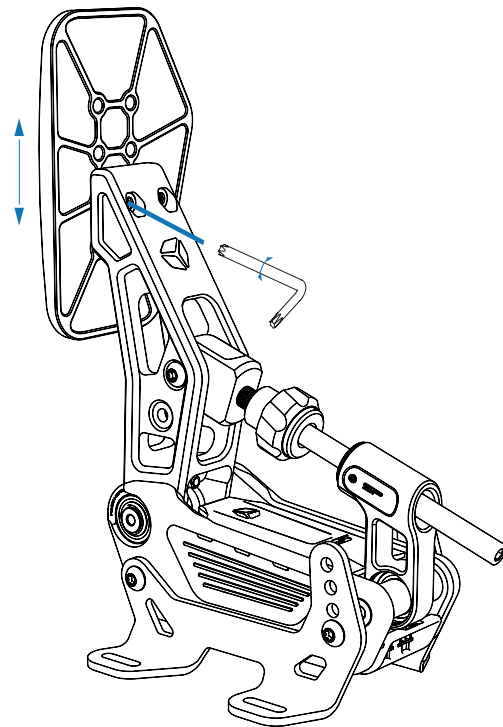

2.2 Throttle Adjustments

You can set the end stroke of the SP01 throttle pedal via the adjustment knob. This way you can change the pedal excursion angle as far as 10 degrees.

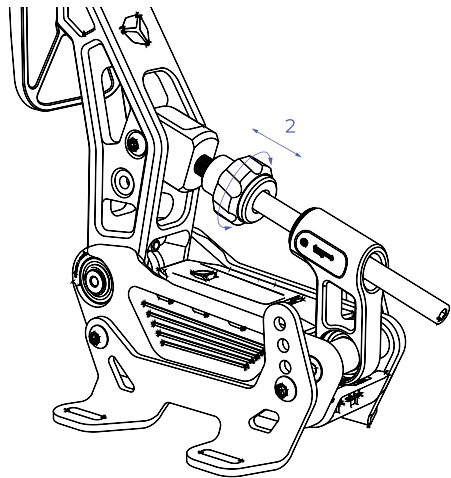

You can also set the spring pre-load (and also the return speed) using the supplied HEX4mm L key on the screw in the front of the pedal.

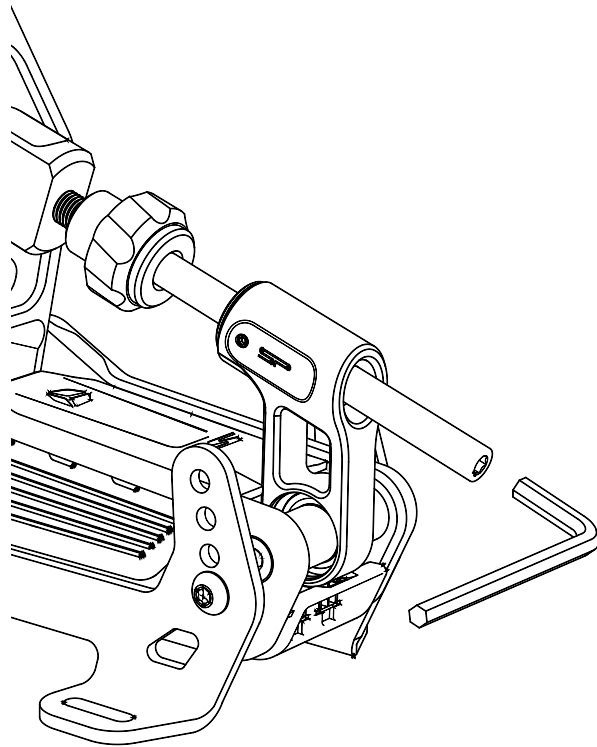
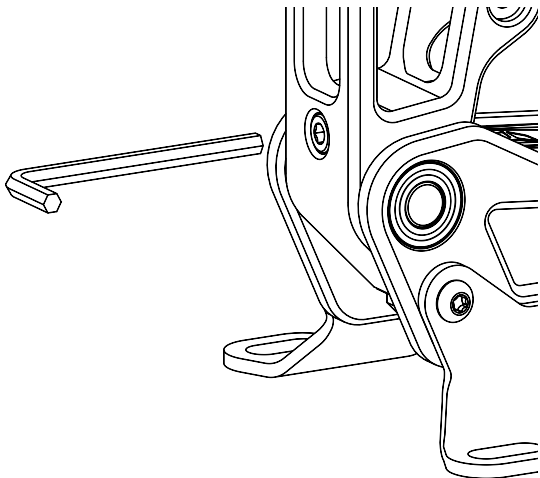

You will also be able to reduce your throttle full throw mounting an additional throttle washer that you can find in your base kit, or reduce it removing the one present!

Doing so is easy: use your HEX4mm L key to untighten the central shaft, remove it and replace the elements.

IMPORTANT:

After every adjustment is necessary to calibrate the throttle again in the software.

When tightening the central shaft, make sure you don't use excessive strength to avoid stripping the thread.

Everytime you adjust or change the brake components and characteristics, please tighten up the blue and the black nuts as hard as possible, so they work in the intended way.

2.3 Brake Adjustments

You are supplied with Elastomers, Springs and Washers to customize and adjust the SP01 brake pedal, specifically:

- ✔ 1 Soft Yellow Elastomer
- ✔ 1 Medium Red Elastomer
- ✔ 1 Hard Blue Elastomer
- ✔ 1 Hard Blue Spring
- ✔ 3 Protective Washers (Large)

These elements can be changed, installed and mix-matched to obtain the perfect resistance for the taste of every driver. Along with every spring and damper you will also need to mount the relative self-centring washer with the flat surface outward-facing. When first installed, the rubber dampers will initially need a break-in period and may seem slightly deformed: do not worry, as this is normal and only temporary.

The correct procedure to replace the elements is to unlock the central shaft using the HEX4mm silver key (rear side) and untighten the pre-load knob completely. Then you can easily unscrew the central shaft itself using your bare hands and remove it directly. At this point you can easily take out the pre-load knob and the elements and replace the ones that you wish to change.

Mount the shaft, the elements and the preload knob back again and tighten the shaft into the pre-load by hand. Secure everything with a small tightening via the HEX4mm key and you're done!

IMPORTANT:

Always remember to install the correct self-centring washer along with the compressible elements you wish to use. If you have any doubt on the correct mounting of the brake shaft and elements, please consult our interactive guides on our website.

When re-tightening the central axis, be careful of your strength: using excessive force may result in stripping the shaft thread, or make the break not work correctly damaging the components.

2.4 Damper Settings

The Damper setting can be changed simply turning the red setting ring on the damper itself. You can choose from 16 total values, going from 0.0 (the less intrusive) to 6.0 (the most intrusive) and all values between.

IMPORTANT:

For the most optimal configuration we suggest to use a low setting, between 0 and 2. Higher values can result in a too much intrusive hydraulic dampening. It can happen in the first days of use for a small leaking of oil to appear from the hydraulic damper. That is normal for the assessing period: simply clean the part and you will be good.

2.5 The Importance of Customization

Thanks to our accessory kit (base and performance) you have great possibility for customization.

If you purchased the SP01 Performance Kit or also with your base customization kit you will have in your hands multiple combination to ensure that you find your perfect fit. In the SP01 Performance Kit specifically you will find additional elements that will incredibly increase your customization capabilities.

Specifically:

Spring Kit (3 pieces)

- 🔩 1 Soft Red Spring
- 🔩 1 Medium Yellow Spring

Elastomer Kit (3 pieces)

- 🔩 1 additional Soft Yellow Elastomer
- 🔩 1 additional Hard Blue Elastomer

9 additional Protection Washers (4 Small, 2 Medium, 3 Large)

2 Tuned Expansion Cups (1 Soft Black, 1 Hard Red)

IMPORTANT:

Just a couple of pointers in choosing your own combination:

- ✔ Springs are softer than the respective Elastomers
- ✔ Small washers go only with the soft red and the medium yellow springs
- ✔ Medium washers go only with elastomers when accompanied by a Tuned Expansion Cup
- ✔ Large washers go with elastomers only when NOT accompanied by a Tuned Expansion Cup, or go always with the Hard Blue Spring
- ✔ Spring or Elastomers that go inside the preload knob only need protective washer in the opposite side.
- ✔ Elastomers are slightly conical: only one face mount to the respective washer 100% perfectly, the other side you will always experience a little gap.

2.6 About your Tuned Expansion Cups

Tuned Expansion Cups can make the difference in tightening your braking!

Their functionality is quite straightforward: the Tuned Expansion Cups are created to contain your elastomers stopping their natural expansion when compressed.

The difference between the Soft Black and the Hard Red is just a matter of millimetrical size of the gap they leave to the elastomer compression.

Mounting them is also very easy: make sure you remove the End Axis Sleeve (or Bush) from the Black Conical piece and block the Expansion Cup between the two. Then you can mount it back again and you're good to go!

IMPORTANT:

If you have any doubt on the correct mounting of the T.E. Cups please consult the interactive guides on our website.



www.cubecontrols.com