

User Guide

GT-X eSports Racing Wheel

Due to continuous improvement, the actual product may differ from the manual.

This manual is for reference only.

For info or support contact us at

hello@cubecontrols.com

or visit us at

www.cubecontrols.com

SAFETY NOTICE

Please read the Manual carefully before you use the racing wheel.

Please do not open the racing wheel, otherwise the supplier will not afford warranty service.

This product does not have waterproof function, please keep it away from rain, moisture and other items containing liquid such as vape, cup and so forth.

This wheel is designed for simulation use only.

Disconnect the USB cable from both sides if you will not use this product for a long time.

Should you find any problems in your wheel, please contact us at **hello@cubecontrols.com**, do not repair it by yourself.

INTERFACE INTRODUCTION

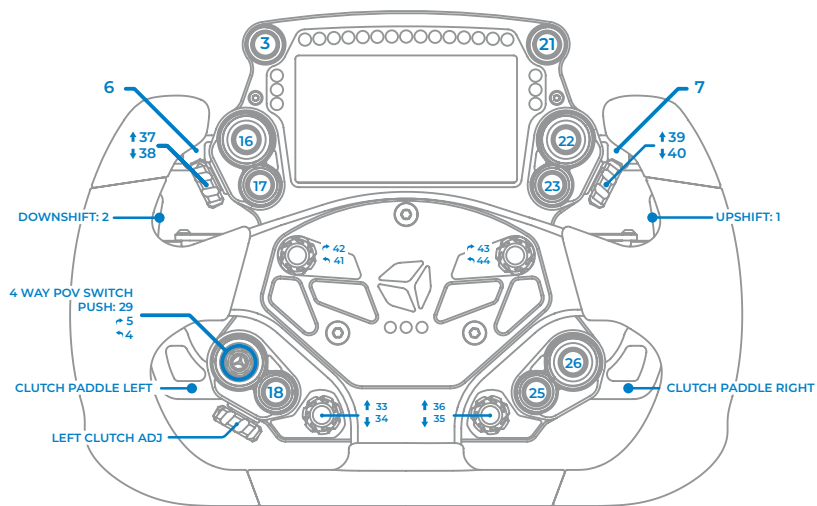

Operating the launch control system:

The maximum value of the left clutch paddle can be adjusted with the respective thumb knob. Therefore, if the clutch knob is set in the middle of its travel, when fully depressing the left clutch paddle, its value will go from the minimum to the value set by the clutch knob, which is middle in this example. The right paddle always works in a range from min to max travel, no matter how the clutch knob is set. This system allows the user to mimic the launch control system used in F1 cars until 2015, where it was possible to set the clutch bite point.

Finding the correct clutch knob setting:

In a practice session, set the clutch knob at around 50% of its travel, fully depress both clutch paddles, engage first gear, reach the optimal engine RPM, release the right clutch paddle. As the car starts gaining speed, release the left clutch paddle and shift gears as normal. If you notice that the clutch starts slipping too much, you will need to decrease the left clutch paddle max value by turning downwards the clutch knob. If you notice that the engine drops quickly in RPM, then you will need to increase the clutch slippage by turning the clutch knob downwards.

This value is typically different for each car.

USB CONNECTION

Connect the steering wheel by only using the provided cable.

Please note that the wheel connector it's keyed as the picture below, so it fits only one way.

Once the plug it's correctly seated into the body receptacle, secure it by turning the retaining ring as bottom right picture.

Try to install the USB coiled cable by wrapping it loosely on your FFB motor shaft/adapter in such a way that it will not suffer any strain even when doing full opposite steering rotations.

Remember to follow these instructions to prevent any kind of damage to your cable.

IMPORTANT: do not over-tighten the ring. Just screw it completely until it stops rotating, do not apply excessive force.

Alignment key

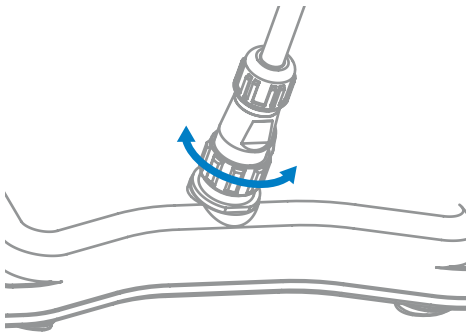
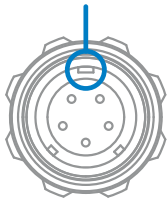

CONNECTING THE WHEEL

Each GT-X steering wheel is provided with a dedicated Y style splitter USB extension cord.

User must use this cable to connect the GT-X wheel to your pc, otherwise if plugged directly to a standard front/back panel USB port it might not work as expected due to the port not being able to supply enough power.

Just plug the two USB-A plugs into your PC, preferably the back panel ones, and connect the coiled cable to the USB-A female connector.

Please avoid any additional extension cords, supplied coiled cable must connect directly to the supplied USB splitter.

BEFORE FIRST USE

The Formula CSX steering wheel needs the Ultimate Game Tech (UGT) software to display data streamed from the simulator. It's also a needed tool useful to customize and configure various options.

It can be downloaded from **ultimategametech.com**

On the same website, there is a quick introduction on the Layout Generator, and a useful general guide on the UGT software.

On the left side of the new window as highlighted in the next screenshot there is the setting you need to adjust, “Digital Switch Point”.

Usually the ideal value is 50, and all GT-X steering wheels are factory programmed with such a value.

If for some reason you are experiencing the shifter button not being recognized properly you must lower the value.

Alternatively if the shifter button is detected as always pressed, you must increase the value.

It’s best to do this increasing/ decreasing at around 5 steps at a time and then test if the shifter is working correctly.

Once the correct value has been found, hit “Save Settings” at the bottom of the window.



WHEEL INSTALLATION

Our universal hub on the back of the wheel body allows the user to install various adapter, or even connect it directly to your FFB base.

Highlighted in blue the M5x0.8 metric holes. In gray, 5,5mm through holes. Both of them are available in 70mm or 50.8mm bolt pattern.

Through holes are rotated by 180°, so flipping your adapter to match the wheel hub may be needed.

Please refer to your adapter or motor manufacturer to ensure compatibility.

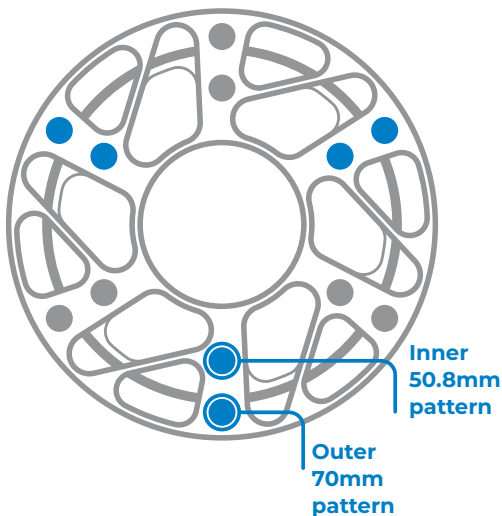

PADDLES ADJUSTMENT

Shift paddles can be easily adjusted to better suit your hand size and driving preferences.

T10 drive needed.

Length can be adjusted by slightly loosening the two screws highlighted in the right picture, and sliding forward/backwards the carbon paddle.

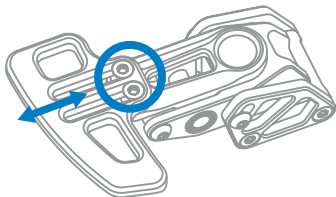

Reach can be adjusted by slightly loosening the screw highlighted as the right picture and the one on the opposite side of the shifter as pointed by the small arrow, then rotating the lever body upwards/downwards. You may need to apply a bit of force. Make sure to firmly secure the screw once the adjustment has been made.

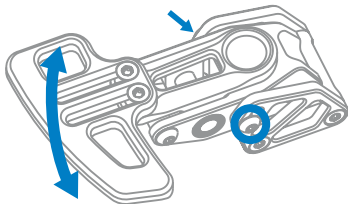

R-spec shifters features an adjustable stop end to better suit driver preferences.

Simply loosen the two screws as pictured on the right and slide the stop end upwards/downwards. Once the adjustment has been made, make sure to tighten the screws.

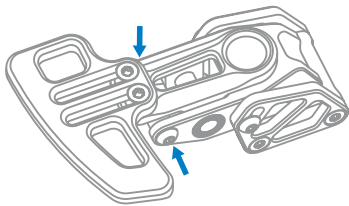

USEFUL TIPS

Each wheel comes with a full sheet of stickers and a set of plastic tweezers useful to install them as your liking.

Before applying the sticker make sure the surface it's clean.

Black and white long labels are designed to be placed over the dial setting name:

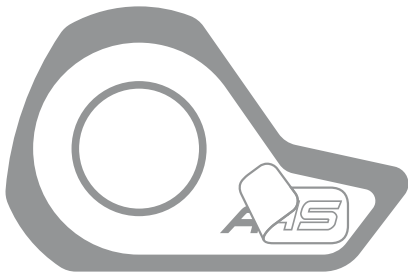

Make sure your rig is grounded correctly. Main wheel body and hub are connected to the wheel own USB ground. Each wheel comes with an auxiliary USB connector that comes out from the main hub. This will be used with our Cube Controls quick release kit.

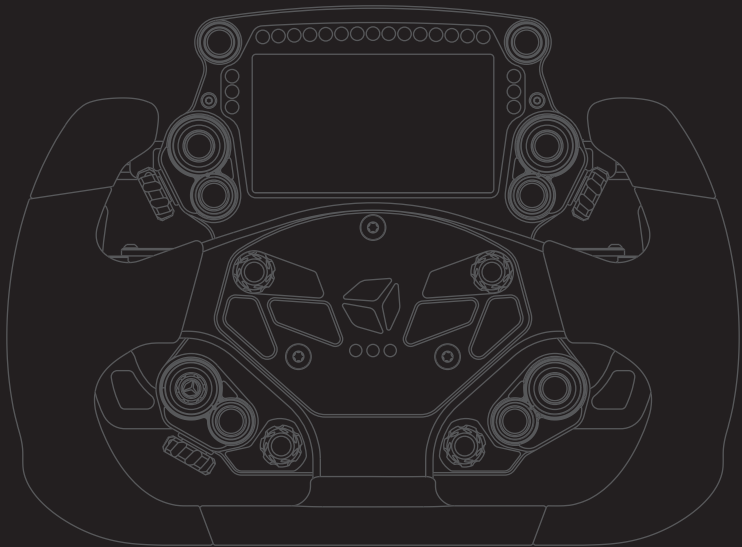

WWW.CUBECONTROLS.COM